

USER AND INSTALLATION MANUAL

of the in-flight electrically adjustable propeller

DuoMax

Serial no.:

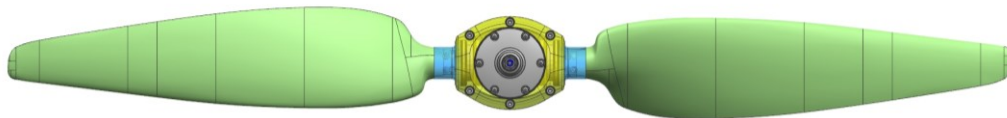

TL-ULTRALIGHT s.r.o.
Airport 515, Pouchov
503 41 Hradec Kralove
CZECH REPUBLIC
Tel.: +420 495 218 910
Fax.: +420 495 213 378
www.tl-ultralight.com

	Document: User and installation manual	Type of propeller: DuoMax
---	---	------------------------------

Intentionally blank

P4/18/005CJ	Revision number: -	Original Issue Date: 30.11.2018 Revision Date: -	2/35
-------------	-----------------------	---	------

Content

Content.....	3
List of changes	5
General information	6
1. Introduction.....	6
2. Certification	6
3. Alerts, warnings and notes.....	7
4. Description and determination of the propeller	7
5. Technical datas.....	8
6. Propeller control.....	9
7. Propeller marking.....	9
7.1. Propeller hub marking.....	9
7.2. Propeller blade marking.....	10
8. Propeller construction	10
8.1. Propeller blades.....	10
8.2. Propeller hub.....	11
8.3. Pitch control mechanism.....	12
8.4 . Pitch control servo motor subassembly	12
8.5. Propeller spiner	13
8.6. Propeller wiring with control and controller.....	14
9. Emergency procedures.....	15
9.1. Vibrations.....	15
9.2. Defect in AUTO mode.....	15
9.3. Functionless pitch adjusting.....	15
10. Usual procedures.....	16
10.1. Pre-flight inspection.....	16
11. Propeller service and maintenance.....	17
11.1. Periodics inspections.....	17
11.2. Special inspections.....	17
11.3. General repair.....	18
11.4 Cleaning and care.....	18
12. Admissible repairs	19
12.1. Propeller spinner cover	19
12.2. Change of parts	19
12.3. Propeller blades repair	19
13. Possible defects and probable causes.....	20
14. Transport and storing	22
14.1. Propeller transport.....	22
14.2. Propeller storing conditions	22
15. Propeller installation	23
15.1. Removing of wrapping and propeller preservation	23
15.2. Installation of servo motor with holder.....	23
15.3. Propeller installation onto the propeller boss.....	25

15.4. Install the Propeller Control Axis26
15.5. Cleaning of bearing area28
15.6. Propeller installation onto the propeller boss.....28
15.7. Nut releasing31
15.8. Maximum speed check31
15.9. Detected speed are higher than given tolerance.....32
15.10. Detected speed are lower than given tolerance.....33
15.11. Nut tightening34
15.12. Propeller spinner cover34
15.13. Inspection and record.....35

List of changes

The user of the propeller is responsible for keeping the manual in force according to the issued changes. The changes or revisions can be issued only by the producer of the propeller. Up-dating of the manual is recorded in following table. Valid revision of this manual, so as the service bulletins and service advicements are available free on www.tl-ultralight.com.

No of change.	Date of issue	Revised pages	Date of insert	Signature
-	30.11.2018	-	30.11.2018	origin. issue

General information

1. Introduction

The aim of this user and installation manual issued by the producer of the propeller is to introduce the electric adjustable propeller DuoMax. The manual provides basic information for usage, maintenance and installation of the propeller and its accessories. This information shall ensure the user the most effective utilization of the propeller. All actions relating to the operation, installation and maintenance of the propeller must be done according to this manual. The actions not mentioned in this manual can be realized only by the producer or authorized service. The manual is divided thematically into the individual parts which are further divided into points according to the importance and relevance of the processed topic.

WARNING:

This product is designed for installation on the aircraft which is certified in light sport aircraft and ultralight category. It is not subject to approval of Civil Aviation Authority Czech Republic and it is operated on user's own risk.

NOTE:

Illustrations, pictures and drawings in this manual only serve as an example of displayed object and cannot be considered for a product or its part as binding.

2. Certification

This propeller was approved by the Light Aircraft Association of Czech Republic according to the regulation UL-2 „Airworthiness requests SLZ“. Type certificate no. **ULL 01/2019** was issued on 7.1.2019.

	Document: User and installation manual	Type of propeller: DuoMax
---	---	------------------------------

3. Alerts, warnings and notes

Following definitions are specified for alerts, warnings and notes in the manual:

ALERT:

Overlooking the corresponding procedure leads to an immediate or significant decrease in flight safety.

WARNING:

Overlooking the corresponding procedure leads to a smaller, shorter or longer decline in flight safety.

NOTE:

Describes notes of some extra points which are not directly related to flight safety, but are important or unusual.

4. Description and determination of the propeller

The DuoMax propeller is a 2-blade tractor configuration in-flight adjustable flight propeller. The propeller hub is from Al alloys and consist of a top and bottom flange with a lid. There are pitch control mechanisms inside the hub. Servo actuator increases the pitch adjusting, in the opposite direction the propeller blades are adjusted with a resistance of a spring located inside the hub. The blade consists of a root part made of steel and composite blade itself. The blade is fastened to the hub using a pair of axial bearings which allow adjusting the pitch. The Servo actuator and kinematic gearing of its movement is located out of the propeller hub over the engine gear box and adjusting the pitch is controlled by a hollow axis.

The propeller is designed for following types of engine:

Rotax 912 UL	80 HP
Rotax 912 S	100 HP
Rotax 912 iS	100 HP
Rotax 914	115 HP

ALERT:

Installation on other types of engine must be first consulted with the producer of the propeller.

P4/18/005CJ	Revision number: -	Original Issue Date: 30.11.2018 Revision Date: -	7/35
-------------	-----------------------	---	------

5. Technical datas

Sense of rotation	clockwise (from the pilot view)
Propeller installation orientation	Tractor
No. of blades	2
Diameter	1708 mm
Max. absorbed engine power	115 HP
Max. propeller speed	2387 ot/min
Pitch control range	10°
Adjust speed from one extreme position to the another – with load	4,6 s
Operating temperature range	-25 ° up to +40 °C
Weight of propeller	8,73 kg
Weight of propeller control servo actuator	1,25 kg
Weight of propeller's spin	0,5 kg
Outer diameter of propeller's spin	Ø 235 mm or Ø 320
Diameter of mounting flange	Ø 124 mm
Driving pins (pitch circle)	Ø 13 mm (101,6 mm)
Fixing screws	M 8
No. of pins/fixing screws	6

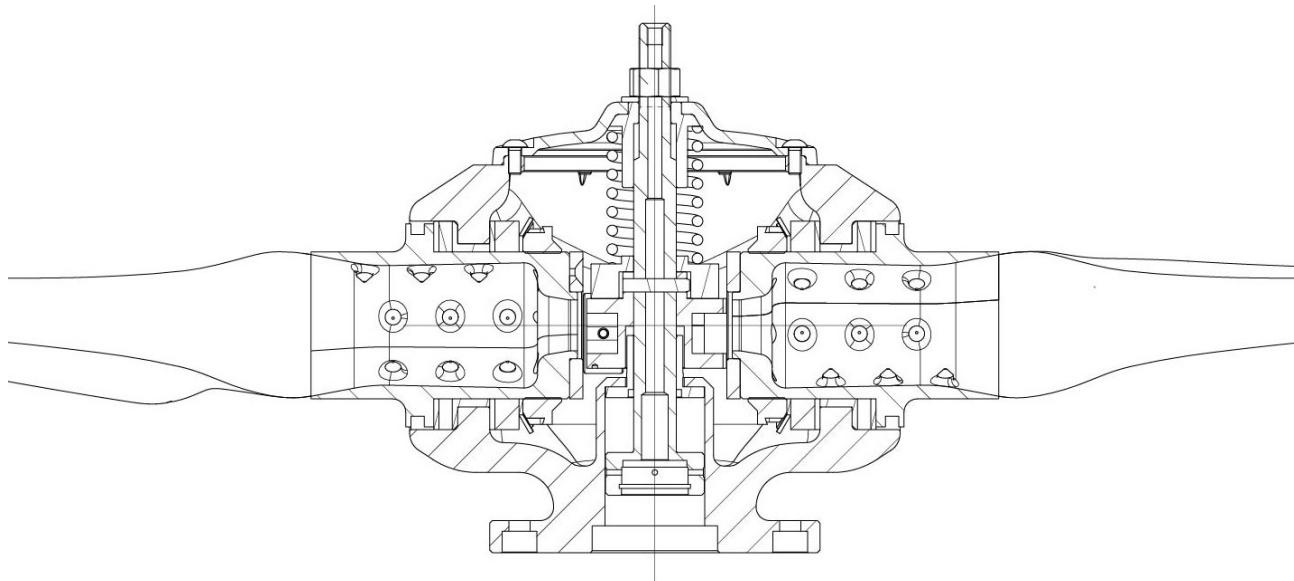

Picture no. 1 DuoMax propeller cut

P4/18/005CJ	Revision number:	Original Issue Date:	30.11.2018	8/35
	-	Revision Date:	-	

	Document: User and installation manual	Type of propeller: DuoMax
---	---	------------------------------

6. Propeller control

Propeller speed are automatically kept by the electronic controller PR 2 - TL in selected position (Constant Speed mode) in various flight modes. So the propeller operates in the constant speed mode.

6.1. Manual control mode

Selects by switching to MANUAL. In this mode, the desired propeller speed can be adjusted smoothly by the control lever (the propeller control lever is usually positioned adjacent to the gas lever). The position of the small sheet setting angle is signaled by the lighted diode normally placed on the dashboard.

6.2. Auto-control mode

Switches to AUTO. Propeller speed is automatically maintained at the selected value (Constant Speed mode) with different flight modes by the electronic controller PR 2 - TL. The propeller therefore operates in steady-speed mode.

7. Propeller marking

7.1. Propeller hub marking

The number is marked on the front cap of the hub (see an example):

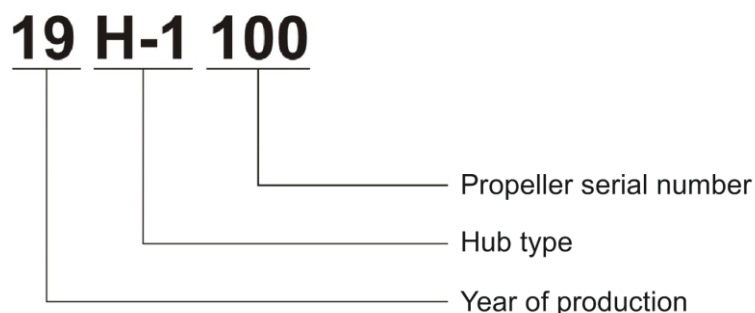

P4/18/005CJ	Revision number: -	Original Issue Date: 30.11.2018 Revision Date: -	9/35
-------------	-----------------------	---	------

7.2. Propeller blade marking

The number is marked on the root part of the blade: (see an example):

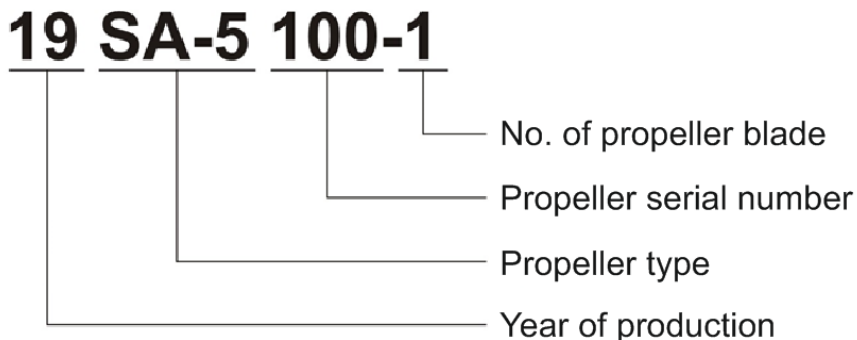

NOTE:

The marking code of the propeller except the last symbol must be identical to the code marked on the propeller hub. Otherwise the propeller was adjusted in an unauthorized way and it is not operated according to the instructions given by the producer.

8. Propeller construction

The propeller assembly consists of following main structural units:

- 1) Propeller blades
- 2) Propeller hub
- 3) Pitch control mechanism
- 4) Pitch control servo actuator subassembly
- 5) Two-piece propeller spinner
- 6) Propeller wiring with control and controller

8.1. Propeller blades

The propeller blades consist of a root part made of steel and carbonic composite blade itself. These two parts are inseparably joined. The blade's root part forms the bearing area for a pair of axial bearings to fasten the blade in the hub and joining area for excentric control of building the blade. The space between the hub and the blade is protected by a rubber O-ring sealing to avoid entering of impurities.

P4/18/005CJ	Revision number: -	Original Issue Date: 30.11.2018 Revision Date: -	10/35
-------------	-----------------------	---	-------

Propeller blade leading edge is protected against the wear-out of the blade in this part by a really resistant layer. The propeller blade surface is produced in a polished white design, the back side is in grey dull colour to avoid reflections. The ends of blades are supplied with colour stripes.

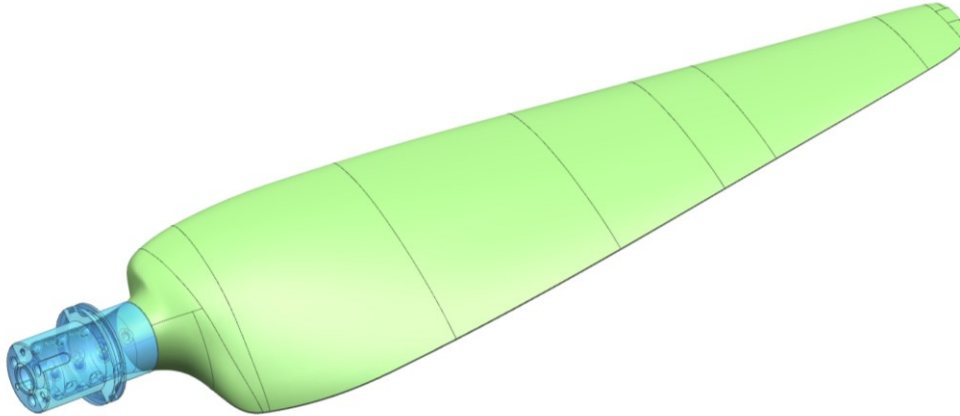

Picture no. 2 DuoMax propeller - blade

8.2. Propeller hub

Propeller hub is made from AL alloys and consists of top and bottom flange produced by a mechanic tooling on CNC machines. The bottom flange is in the part adjacent to the engine controller supplied with holes fit for installation on engines specified in chapter 4.

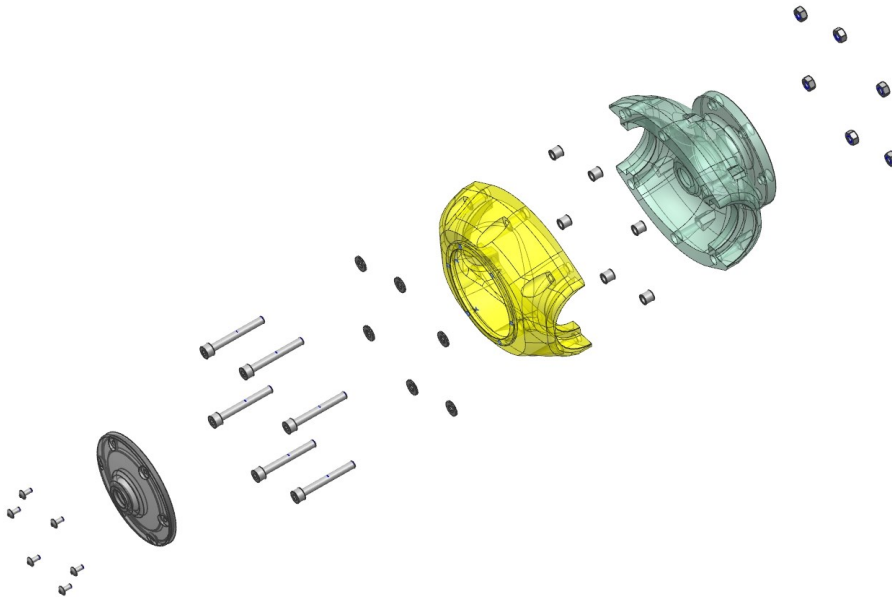

Picture no. 3 Hub of DuoMax propeller

8.3. Pitch control mechanism

The pitch control mechanism is hidden inside the propeller hub and its task is to transfer the advance motion from the servo actuator to the pitch control. This ensemble is accessible after dismantling the flange top part with a cap. A spring which ensures adjusting the pitch towards smaller angles is a part of the subassembly. The construction of the mechanism creates fixed movement stops of the pitch adjusting.

ALERT:

Keeping the requested tolerances during the pitch control mechanism assembly is possible only by the producer or authorized service. Other subjects are not allowed for any manipulation with this subassembly.

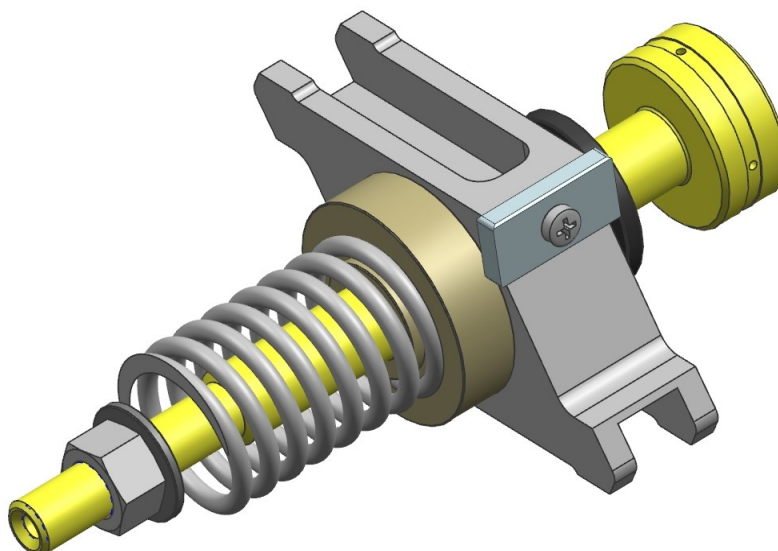

Picture no. 4 DuoMax pitch control mechanism

8.4 . Pitch control servo motor subassembly

The servo motor and kinematic gearing of its movement is located out of the hub above the controller and the pitch adjusting is controlled by a hollow axis of the controller and the propeller. The kinematic gearing consists of balance lever and axis of propeller control. The complete subassembly is fasten by holders to the engine gearbox.

P4/18/005CJ	Revision number: -	Original Issue Date: 30.11.2018 Revision Date: -	12/35
-------------	-----------------------	---	-------

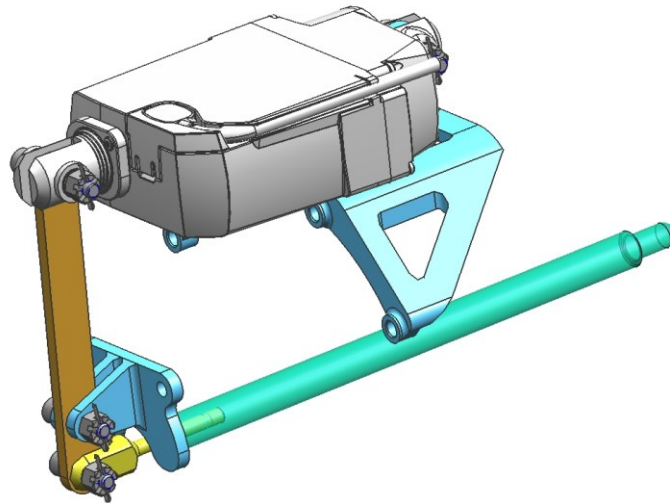

Picture no. 5 DuoMax pitch control servo motor subassembly

8.5. Propeller spinner

The propeller spinner consists of a base and a conical cover. Both parts are produced from glass-carbon composite materials. The propeller spinner is supplied in various colours according to the customer's request.

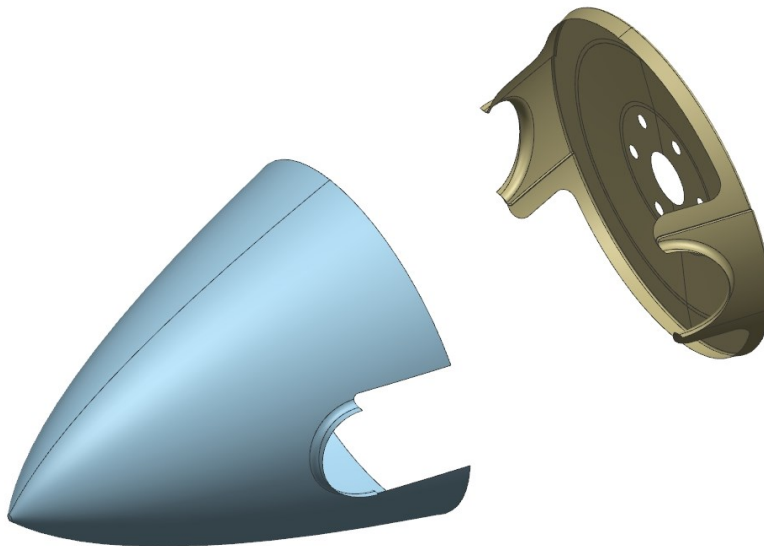

Picture no. 6 Two-piece DuoMax propeller spinner

8.6. Propeller wiring with control and controller

The electrical system operates with 12 V voltage and consists of constant speed unit PR 2 – TL, AUTO/MANUAL and INC/DEC switches, control lever, diode and linear servomotor. The actuator is further connected to the RPM sensor.

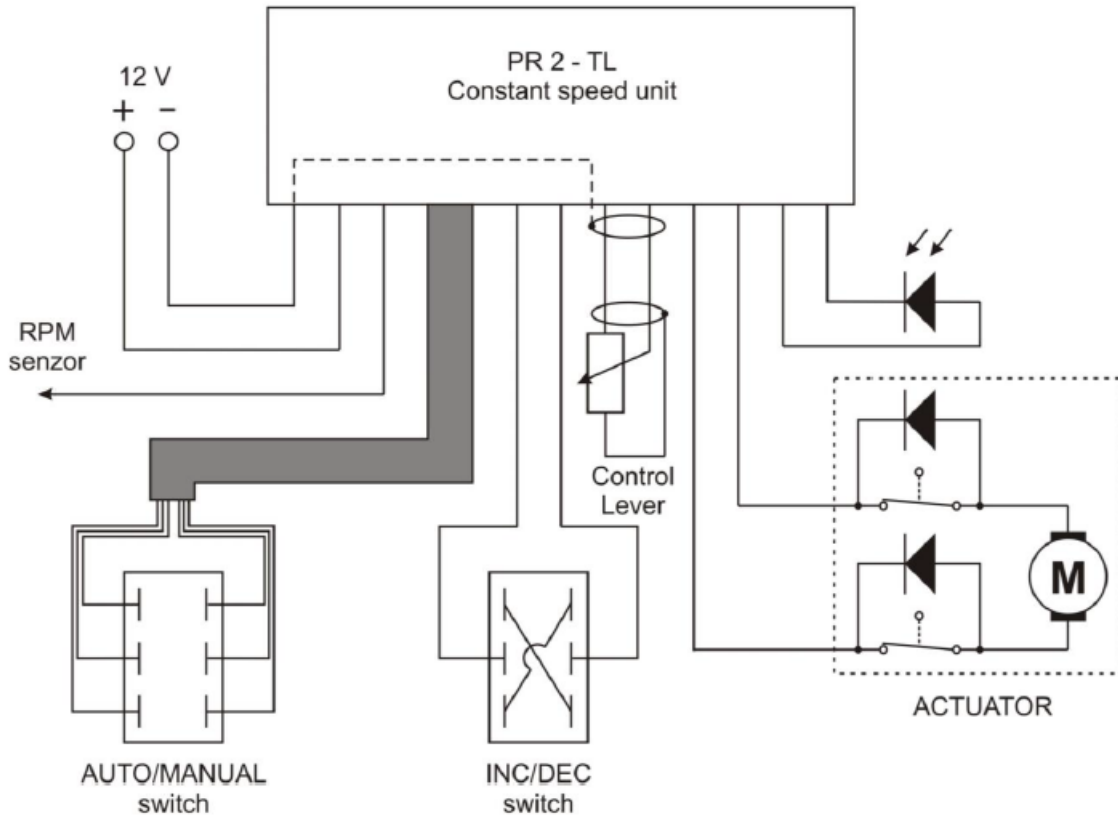

Picture no. 7 DuoMax wiring scheme

NOTE:

The propeller producer recommends to provide the aircraft with a boostmeter. Adjusting the pitch to the appropriate modes may be selected according to the values on this indicator. So there is no excessive engine stress and uneconomic operation of the whole driving system.

P4/18/005CJ	Revision number: -	Original Issue Date: 30.11.2018	14/35
		Revision Date: -	

9. Emergency procedures

This chapter gives procedures and special procedures for case of emergency which may occur. If the pre-flight inspection and maintenance are done properly, the emergency cases of the propeller are rare. If there is an emergency, the basic procedures specified in this manual can be used for eliminating the situation.

9.1. Vibrations

- | | |
|---------------------------------|--|
| 1. Throttle control lever | Set the engine mode in which the vibrations are the lowest |
| 2. Propeller AUTO/MANUAL switch | Switch to MANUAL position |
| 3. Propeller control lever | Set the propeller mode in which the vibrations are the lowest |
| 4. Landing | At the closest airport or appropriate area
(according to the aircraft manual) |

9.2. Defect in AUTO mode

- | | |
|---------------------------------|---|
| 1. Propeller AUTO/MANUAL switch | Switch to MANUAL position |
| 2. MANUAL mode function test | Try carefully the function of adjusting the pitch in the mode |
| 3. Landing | At the closest airport (according to the aircraft manual) |

9.3. Functionless pitch adjusting

- | | |
|---------------------------------|--|
| 1. Propeller AUTO/MANUAL switch | Try carefully the function of the propeller in both modes |
| 2. Landing | At the closest airport or appropriate area
(according to the aircraft manual) |

ALERT:

When the pitch control mechanism does not work the driving unit may have reduced thrust (propeller stucked in high pitch) by lower speeds than usual. Pilot must take this into consideration when landing.

10. Usual procedures

10.1. Pre-flight inspection

Do the inspection systematically before every flight.

1. Propeller blades
Visual check of propeller blades focused on defects (eg. chipped edge etc.) or cracks on the leading and trailing edges and root part.
2. Propeller blades mounting
Check of mounting the blades in the hub. The mounting must be without apparent backlash and without oil leakage.
3. Propeller spinner
Visual check of the spinner and its mounting to the propeller focused on the defects and unwanted releasing.
4. Check of propeller mounting
Check of propeller condition and strenght of mounting to the engine controller and without oil leakage.
5. Check of pitch adjusting
Check of pitch adjusting in the complete range (focused on time needed for adjusting the pitch to the extreme position) after switching on the engine.

ALERT:

Any manipulation with the aircraft via the propeller (eg. wheeling or towing the aircraft via propeller blades) is prohibited. The propeller is not designed for this activity and could be damaged which will significantly influence its safety during next flight operation.

	Document:	Type of propeller:
	User and installation manual	DuoMax

11. Propeller service and maintenance

This chapter contains procedures for proper ground service and maintenance of the propeller recommended and prescribed by the producer. The requests for inspections and maintenance are defined so as the propeller achieves requested outputs and reliability. Realizing by the producer prescribed inspections is a condition for the warranty of the propeller.

11.1. Periodics inspections

All activities mentioned in this chapter can be realized only by persons or subjects with corresponding qualification.

Inspection	Time of operation (h) - period	Provided by	Note
500 hour inspection	- every 500 ± 5 hours of operation	Service centre or producer	Disassembly of the aircraft needed

WARNING:

Records about the realised inspections must be confirmed in the propeller record book.

11.2. Special inspections

Special inspections may be requested by the producer in case of untypical installation or usage of the propeller.

If the propeller speed are exceeded by 10% above the take-off speed for a short term, the authorized mechanic must eliminate the cause of the defect and realize a special inspection.

If the speed are exceeded by 10% above the take-off speed during the operation, the propeller must be immediately put out of operation and sent to the producer for general repair. Send the propeller with a detailed report specifying the cause of speed stalling and the values.

WARNING:

Record about the realised special inspection must be confirmed in the propeller record book.

P4/18/005CJ	Revision number: -	Original Issue Date: Revision Date:	30.11.2018 -	17/35
-------------	-----------------------	--	-----------------	-------

	Document: User and installation manual	Type of propeller: DuoMax
---	---	------------------------------

11.3. General repair

The first general repair must be done after 1500 hours of operation or after 10 years from the propeller's production date (date of production is a part of the propeller serial no). General repair is realised entirely by the producer of the propeller. Subsequent periodic control system is identical to the system of a newly produced propeller or the residual life is determined according to the propeller condition.

WARNING:

Record about the realised special inspection must be confirmed in the propeller record book.

11.4 Cleaning and care

NOTE:

The basic cleaning of propeller blades and the spinner can be done by the user according to this manual.

Clean the exterior surface of propeller blades and the spinner with a cloth damped in tepid water. By higher fouling use ordinary autoshampoo with concentration 2-10% according to the level of fouling and after then wash with pure cold water. Slide protecting covers onto the blades after every ending of flight day.

ALERT:

Do not press on the propeller blades and the spinner when cleaning them and do not use pressure water. It could cause unwanted changes in settings of propeller geometry.

Use of other cleaning agents and diluents is prohibited.

P4/18/005CJ	Revision number: -	Original Issue Date: 30.11.2018 Revision Date: -	18/35
-------------	-----------------------	---	-------

	Document: User and installation manual	Type of propeller: DuoMax
---	---	------------------------------

12. Admissible repairs

The user of the propeller is allowed to make only the below mentioned repairs. Other repairs must be realised by the producer, authorized mechanic or authorized service centre.

12.1. Propeller spinner cover

The cover of propeller spinner can be dismantled easily after removing 8 screws placed on the cover girth. Centre axially the cover of propeller spinner during assembly. The admissible repairs are not valid for the propeller spinner support. Its disassembly requires complete disassembly of the propeller which can be done only by the authorized mechanic.

12.2. Change of parts

The user can change following parts which were supplied by the producer of the propeller: cover of propeller spinner, cabling and propeller control lever.

12.3. Propeller blades repair

The user is allowed to repair only small defects of the protecting slat on the leading edge of propeller's composite blade part. The maximum size of such repair (chipped mass) done by the user is 3 mm. Repair process:

1. Clean and ungrease the damaged place.
2. Fill in the chipped edge with epoxid resin and let it harden.

ALERT:

Do not use local sources (eg. hairdrier) for speeding the process of resin hardening. The propeller blade surface or its finish may be damaged.

3. Regrind the filled place to the shape of propeller blade profile using the sanding paper.
4. Create the protecting layer of paint in the place of repair.

ALERT:

The propeller blades are statically and dynamically balanced from the production. When repairing take notice of not influencing this balance.

P4/18/005CJ	Revision number: -	Original Issue Date: 30.11.2018 Revision Date: -	19/35
-------------	-----------------------	---	-------

13. Possible defects and probable causes

Following possible defects may appear during the propeller's operation and may have described probable causes and possible solutions of elimination.

Defect description	Probable cause	Suggested solution	Qualification needed for suggested solution
Vibrations during flight or on the ground	Static unbalance of the propeller	Check the condition of propeller blades, focus on chipped or broken off parts or damaged surface	Authorized mechanic who solves the possible defect according to the procedures discussed with the producer or the authorized service centre
	Aerodynamic unbalance of the propeller	Check the functionality of adjusting the pitch, focus on smooth and relative synchronisation of adjusting. Do the check on ground with engine turned off.	Authorized mechanic who solves the possible issue with adjusting the pitch according to the procedures discussed with the producer or the authorized service centre
	Engine defect or releasing of engine bedding	Procedure according to the recommendations of engine or aircraft producer	According to the requests of engine or aircraft producer
Propeller blades do not adjust to the requested positions	Defect on pitch control mechanism, wiring or servo actuator	Dismantle the pitch control mechanism, check accuracy and function of wiring, try function of servo actuator	Authorized service centre or producer

Defect description	Probable cause	Suggested solution	Qualification needed for suggested solution
Engine does not achieve prescribed speed by engine test (propeller is „heavy“)	Propeller blades are adjusted to too high minimum angle of theirs possible adjustment	Set up the pitch control mechanism according to instructions in chapter 15	Authorized mechanic, propeller producer or authorized service centre
	Bad engine RPM gauge	Check the functionality of engine RPM gauge, eventually change it	According to the requests of engine RPM gauge producer and aircraft producer
	Decrease of engine output	Check according to instructions given by engine producer	According to the requests of engine producer
Engine rewinds prescribed speed by engine test (propeller is „light“)	Propeller blades are adjusted to too low minimum angle of theirs possible adjustment	Set up the pitch control mechanism according to instructions in chapter 15	Authorized mechanic, propeller producer or authorized service centre
	Bad engine RPM gauge	Check the functionality of engine RPM gauge, eventually change it	According to the requests of engine RPM gauge producer and aircraft producer
Oil leakage	Oil which was used for preservation may flow out of the propeller in the first 25 operation hours	Clean up the propeller according to chapter 11.4.	User
	Defect of rubber sealing O-rings which seal the space between hub and propeller blade	Dismantle the propeller blades from the hub and change the bad sealing O-rings	Authorized mechanic, propeller producer or authorized service centre

Note:

If any other defects occur during the propeller operation, it is necessary to consult their possible reason with authorized mechanic, service centre or producer who suggest further action.

P4/18/005CJ	Revision number: -	Original Issue Date: 30.11.2018 Revision Date: -	21/35
-------------	-----------------------	---	-------

14. Transport and storing

This chapter adjusts by the producer prescribed instructions for propeller transport and storing.

14.1. Propeller transport

The propeller is always supplied as ready-made, except the pitch control servo actuator subassembly, which must be separately installed.

NOTE:

The propeller may be transported to the producer dismantled. The producer is not responsible for any damages caused by the transport or by the unappropriate fixing and placing in a box.

14.2. Propeller storing conditions

A newly produced propeller or propeller after general repair is preserved from the production. Store it in original wrapping in a clean and dry room heated during winter and slightly ventilated. There must not be stored chemicals affecting harmfully the propeller and the blades in the same room. Sharp temperature fluctuation is inadmissible. The wrapping must be stored in bulk, at least 20 cm above the floor and from the room walls.

Table of requested climatic conditions for propeller storing

Temperature range	+5 to + 40 °C
Relative humidity range	45 to 75 %

Propeller with removed original wrapping store like this:

1. In a horizontal position with the propeller hub flange laid on a pad and fixed with six screws M 8. The propeller blades must not be in touch or be supported with any objects. The propeller blades must be covered with protective sleeves.
2. In a vertical position fixed properly with six screws M 8 on the wall. The propeller blades must not be in touch or be supported with any objects. The propeller blades must be covered with protective sleeves.

ALERT:

It is forbidden to store the propeller laying end of one blade on the ground and the second blade leaned on e.g. the wall. This position could affect the geometry of blades adjusting.

P4/18/005CJ	Revision number: -	Original Issue Date: 30.11.2018 Revision Date: -	22/35
-------------	-----------------------	---	-------

15. Propeller installation

This chapter provides by the producer prescribed instructions for propeller installation onto the propeller boss, wiring of control system and pitch control mechanism.

WARNING:

Propeller can be installed on the aircraft only by authorized mechanic, authorized service centre or producer.

NOTE:

Propeller is designed only for installation onto the engines according to chapter 4.

15.1. Removing of wrapping and propeller preservation

Remove the wrapping and propeller preservation and get it out from the transportation box. Check the condition, eventual damages or deformations of the supplied propeller. Check if the supply is complete.

15.2. Installation of servo motor with holder

Install the servo motor holder onto the cover of engine reducer using 4 screws M6 x 50. Tightening torque of the screws is 9,7 N.m. Further install the servo motor on the holder using servo motor case (long), screw M6 x 40, couple of washers and crown nut with pin. Orient the servo motor piston backwards.

Item no.	Item/Subassembly name
1	Servo motor holder
2	Servo motor
3	Servo motor case - long
4	Screw M6 x 40 8.8 DIN 912
5	3 screw M6 x 50 8.8 DIN 912
6	Crow nut M6 ČSN 02 1411
7	Washer M 6

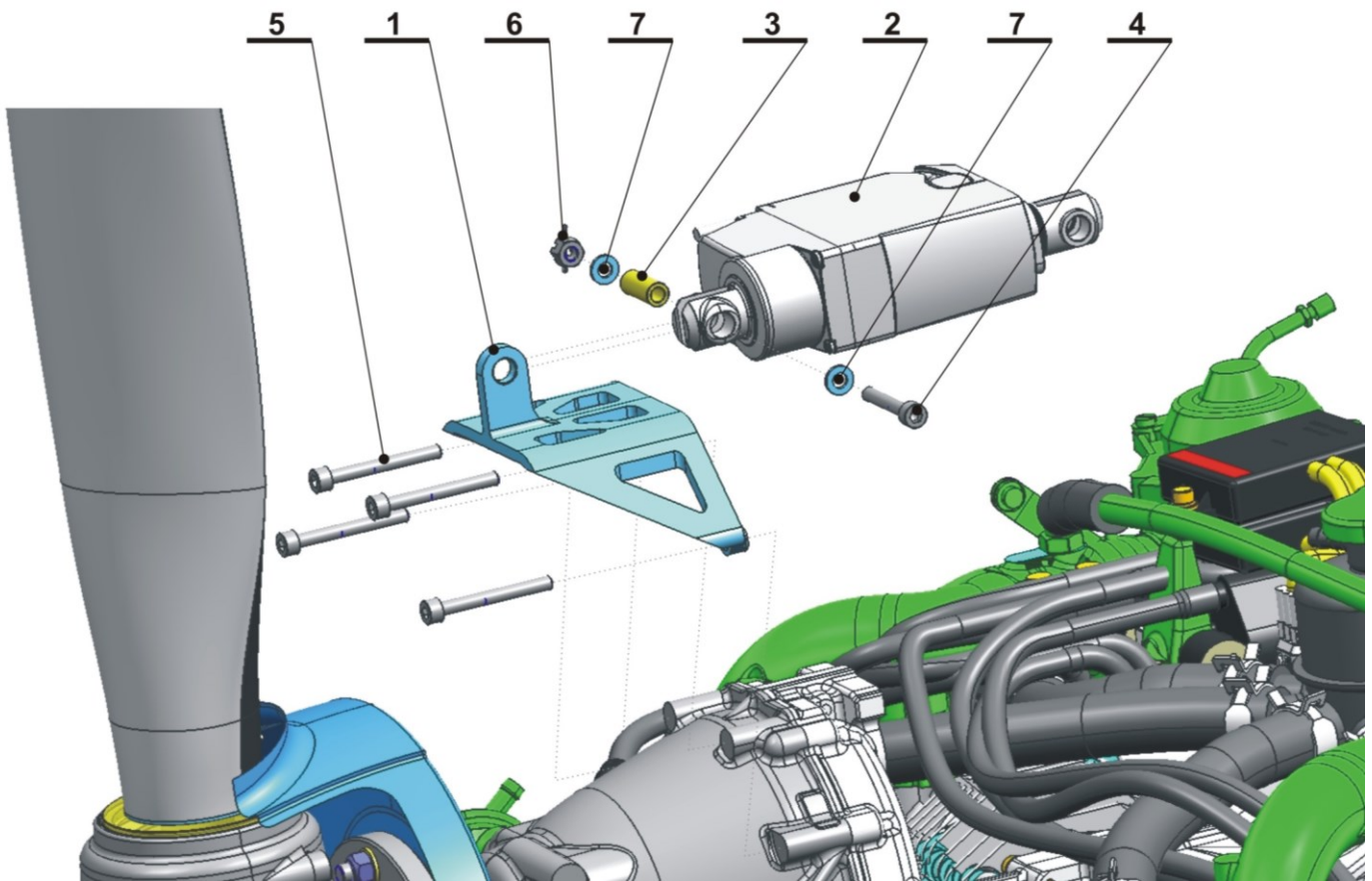

Picture no. 8 Servo motor with holder - assembly



Picture no. 9 Servo motor with holder - assembly

P4/18/005CJ	Revision number: -	Original Issue Date: Revision Date:	30.11.2018 -	24/35
-------------	-----------------------	--	-----------------	-------

15.3. Propeller installation onto the propeller boss

Use the M 6 x 20 8.8 DIN 912 screw on the engine reducer cover to install the servo motor reversing lever retainer part. The tightening torque of the screws is 9.7 N.m. Install the servomotor reversible lever to the servomotor piston with the M6 x 40 8.8 DIN 912 bolt, M 6 castle nuts with a pin and a pair of washers. Replace the actuator lever with the M6 x 27 8.8 DIN 912 bolt, the M6 castle nut with the pin and the pair of washers on the servomotor retaining lever retainer. Around this attachment the reversible lever must rotate freely.

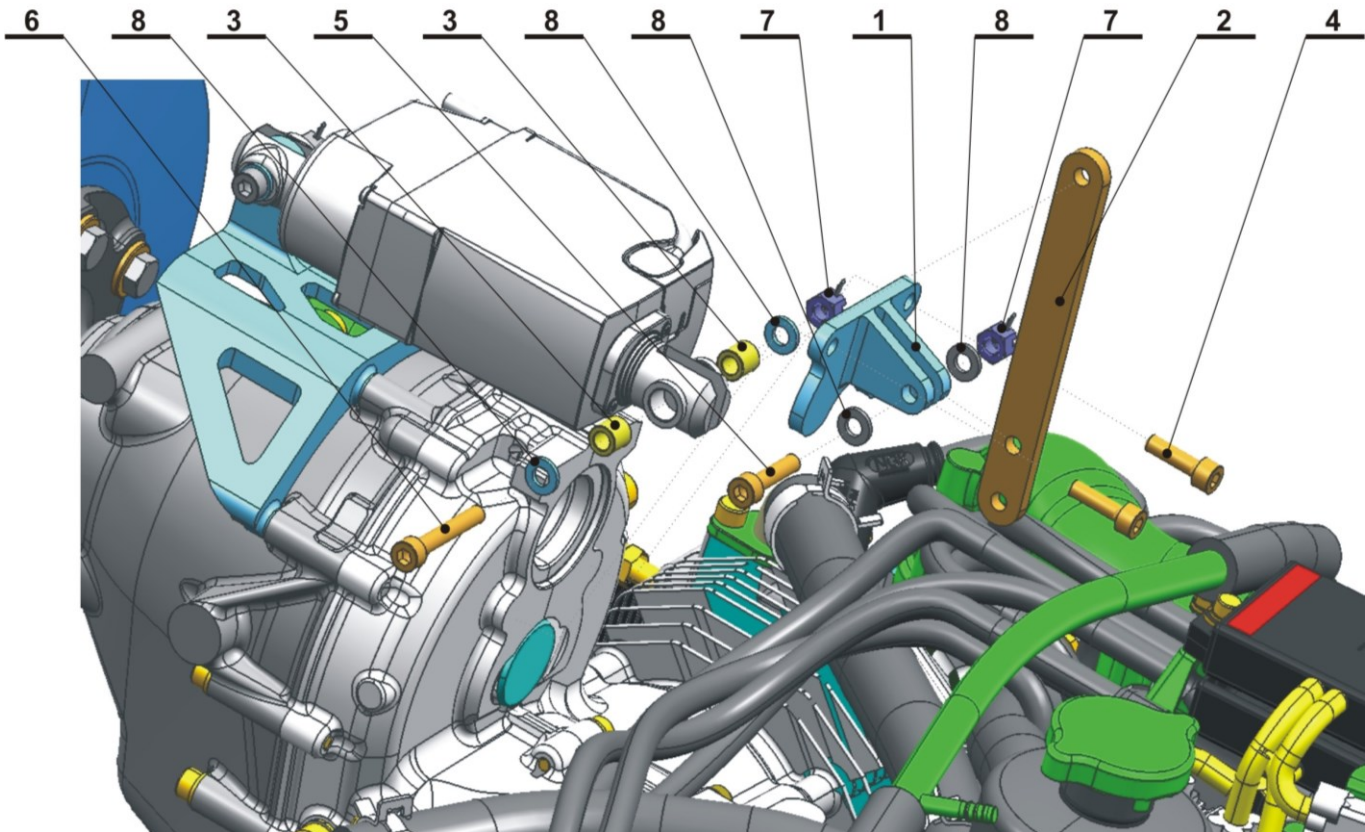

Picture no. 10 Reversible handle of servo motor with holder – assembly

1	Holder of servo motor reversible handle
2	Servo motor reversible lever
3	Servo motor housing – short
4	Screw M6 x 20 8.8 DIN 912
5	Screw M6 x 27 8.8 DIN 912
6	Screw M6 x 40 8.8 DIN 912
7	Crown nut M6 ČSN 02 1411 with pin
8	Washer M 6

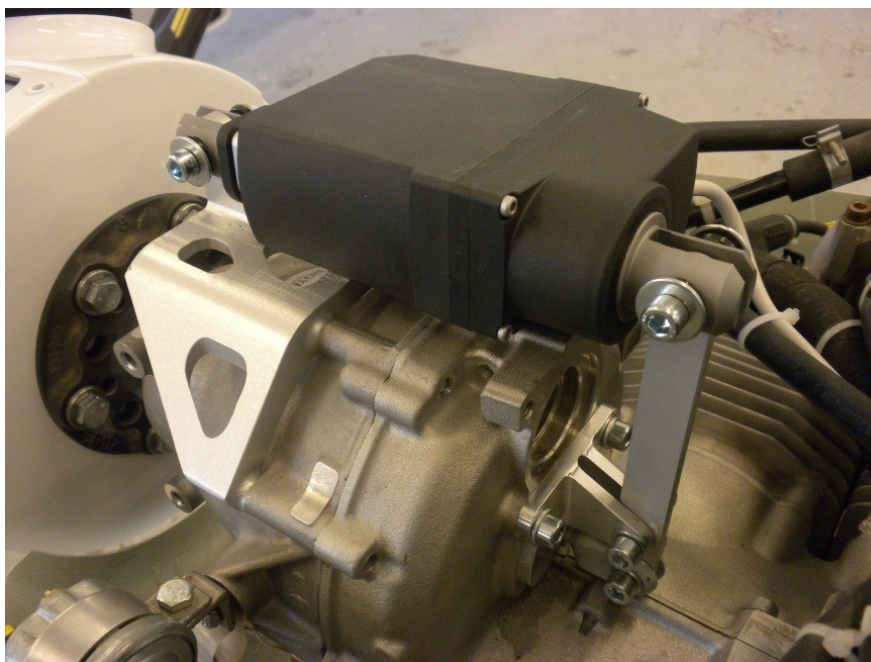

Picture no. 11 Reversible handle of servo motor with holder – assembly

15.4. Install the Propeller Control Axis

Put the propeller control shaft into the hollow axis of the propeller with the fork control and nut M6. Connect the propeller control fork with the servomotor lever with the M6 x 25 8.8 DIN 912 bolt, the castel nut M 6 with the pin and the pair of washers.

1	Axis of propeller control
2	Fork of propeller control
3	Screw M6 x 25 8.8 DIN 912
4	Nut M6 hexagonal ISO 4032
5	Crown nut M6 ČSN 02 1411 with pin
6	Washer M 6

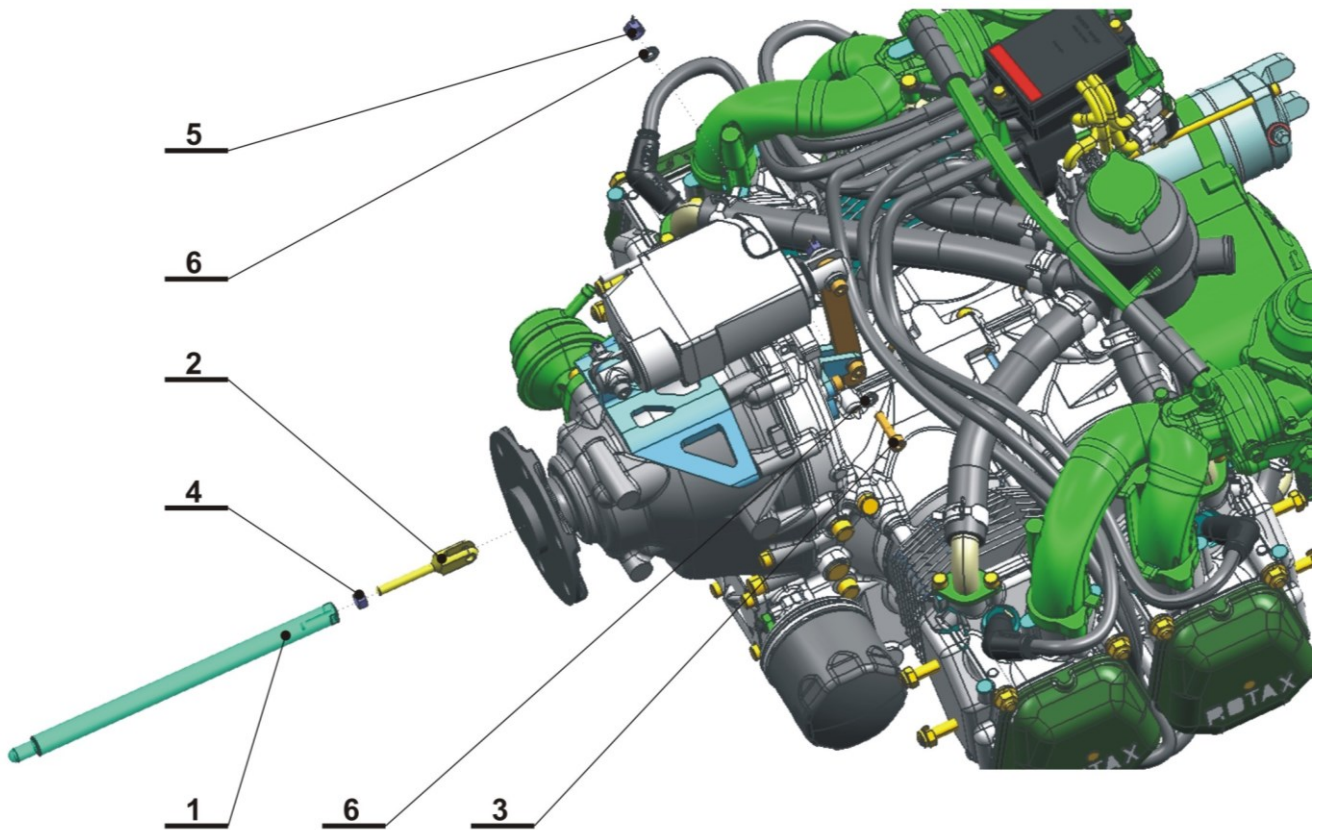

Picture no. 12 Propeller control axis - installation

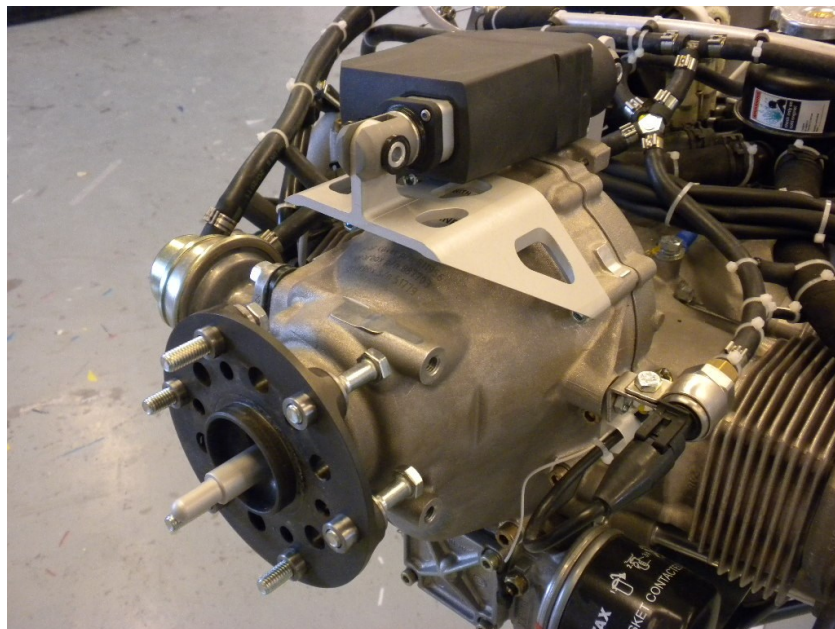

Picture no.13 Propeller control axis - installation

P4/18/005CJ	Revision number: -	Original Issue Date: Revision Date:	30.11.2018 -	27/35
-------------	-----------------------	--	-----------------	-------

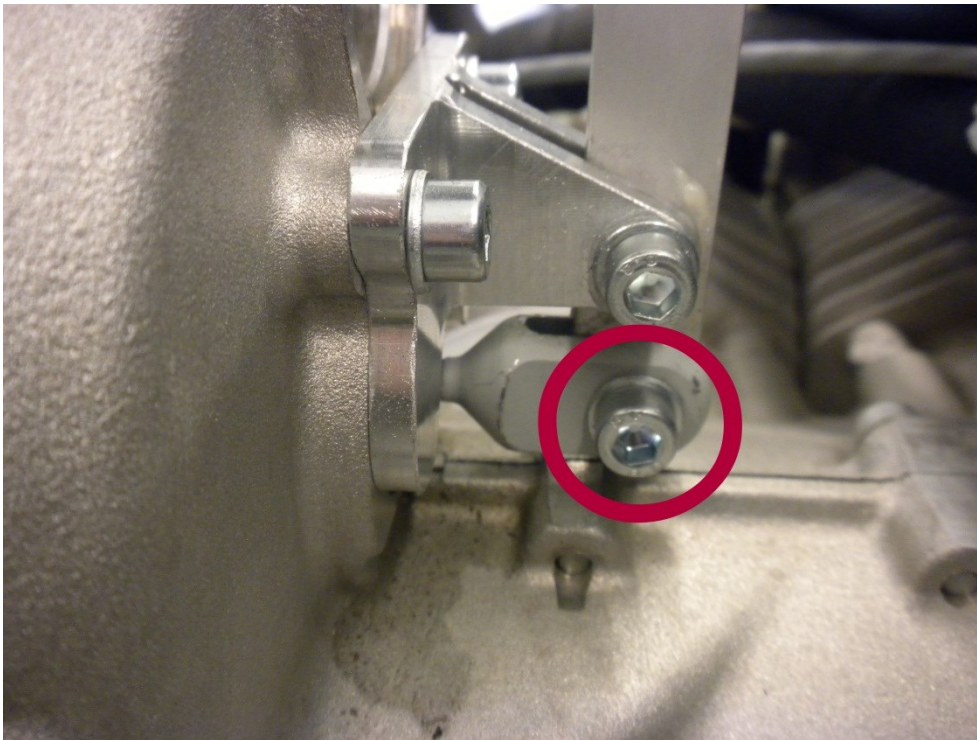

Picture no.14 Propeller control axis – installation

15.5. Cleaning of bearing area

Clean the bearing area of propeller hub flange with centre recess. Clean the bearing area of propeller hub flange with centre area. Check condition of bearing area.

15.6. Propeller installation onto the propeller boss

Put the composite base of propeller hub onto the propeller boss and fix the senary of follower pins into the recess in reducer flange. Finally put the built-up propeller onto the propeller boss with base of propeller spinner. Set the propeller hub position so as the holes for follower pins are aligned and put the propeller hub on them. Fix the joint of propeller and engine with senary of screws M 8 x 40 8.8 ISO 4014 and secure them with metal nuts VM 8 DIN 980 with washers. Tighten the screws according to following instruction scheme with requested tightening torque

ALERT:

Check and tighten properly the screws and nuts after every propeller installation when achieving first 25 operation hours. Partial loss of assembly overlap in the joint of flange and propeller hub may occur after this period. Which could endanger the operation safety.

P4/18/005CJ	Revision number: -	Original Issue Date: Revision Date:	30.11.2018 -	28/35
-------------	-----------------------	--	-----------------	-------

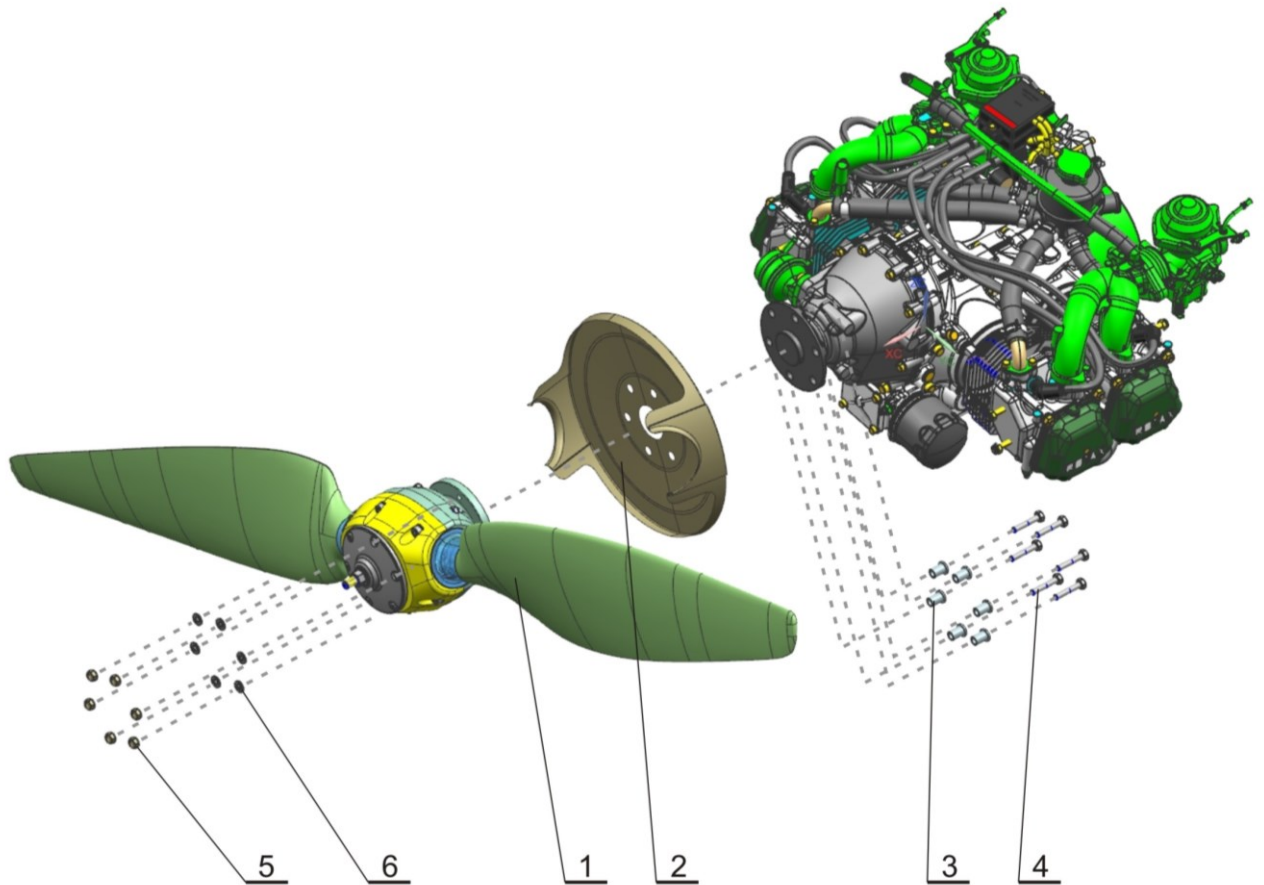

1	Power DuoMax
2	Propeller base
3	Propeller clutch pin with engine reducer
4	Screw M8 x 40 8.8 ISO 4014
5	Self-locking nut VM 8 DIN 980
6	Washer M 8

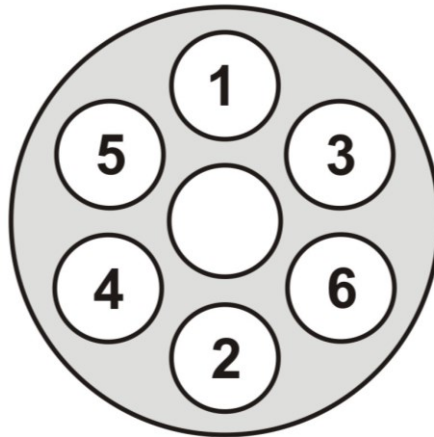

Picture no. 16 Sequence of procedure for tightening the screws

Tightening torque of screws joining propeller with propeller boss	23,5 N.m
--	----------



Picture no. 17 Propeller installation onto the propeller boss

P4/18/005CJ	Revision number: -	Original Issue Date: Revision Date:	30.11.2018 -	30/35
-------------	-----------------------	--	-----------------	-------

15.7. Nut releasing

Release the nut M 12 marked in the following picture.

WARNING:

Do not remove completely the nut M 12 from the axis of pitch control mechanism, only release it.

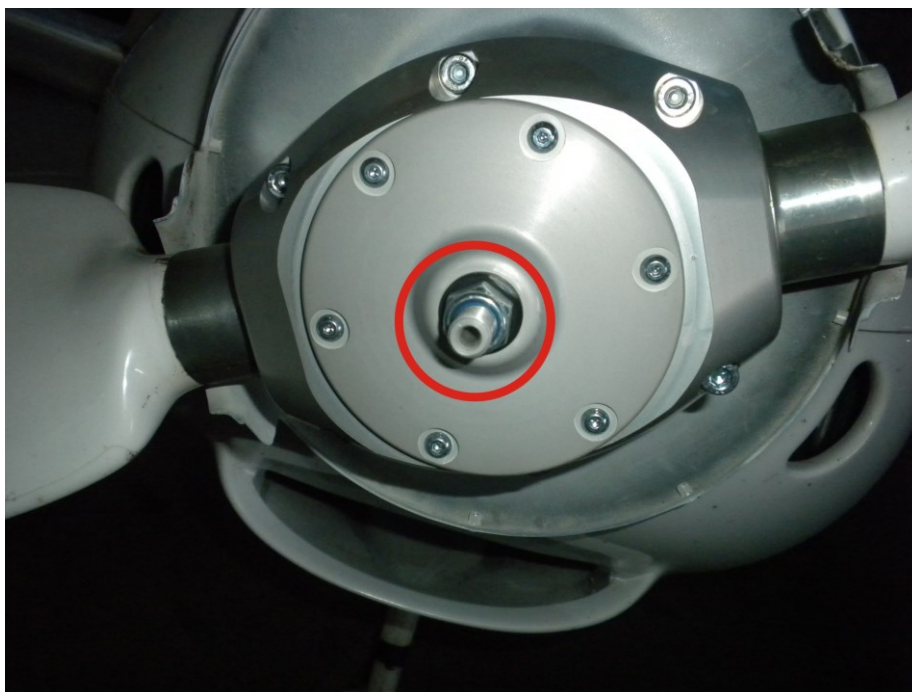

Picture no. 18 Nut M 12 releasing

15.8. Maximum speed check

Set the AUTO/MANUAL switch to MANUAL position and with INC/DEC switch set small pitch of propeller blades adjustment by leaving the servo motor stop not before its backstop.

Remove the textile protective sleeves from the propeller. Start up the driving unit and check carefully the speeds by maximum engine output. Engine speeds must be 5550 – 5600 speed/min. in this mode.

If the detected speed are in tolerance **5575 ± 200 ot/min** follow point **15.11**.

If the detected speed are higher than tolerance **5575 ± 200 ot/min** follow point **15.9**.

If the detected speed are lower than tolerance **5575 ± 200 ot/min** follow point **15.10**.

15.9. Detected speed are higher than given tolerance

In this case it is necessary to dismantle the screws M6 x 25 a M6 x 27 with crown nuts and washers from the servo motor reversible handle. After then it is possible to deflect the whole servo motor and get to the fork of propeller control. Put out the fork by requested extent and fixed it with hexagonal contra nut M6.

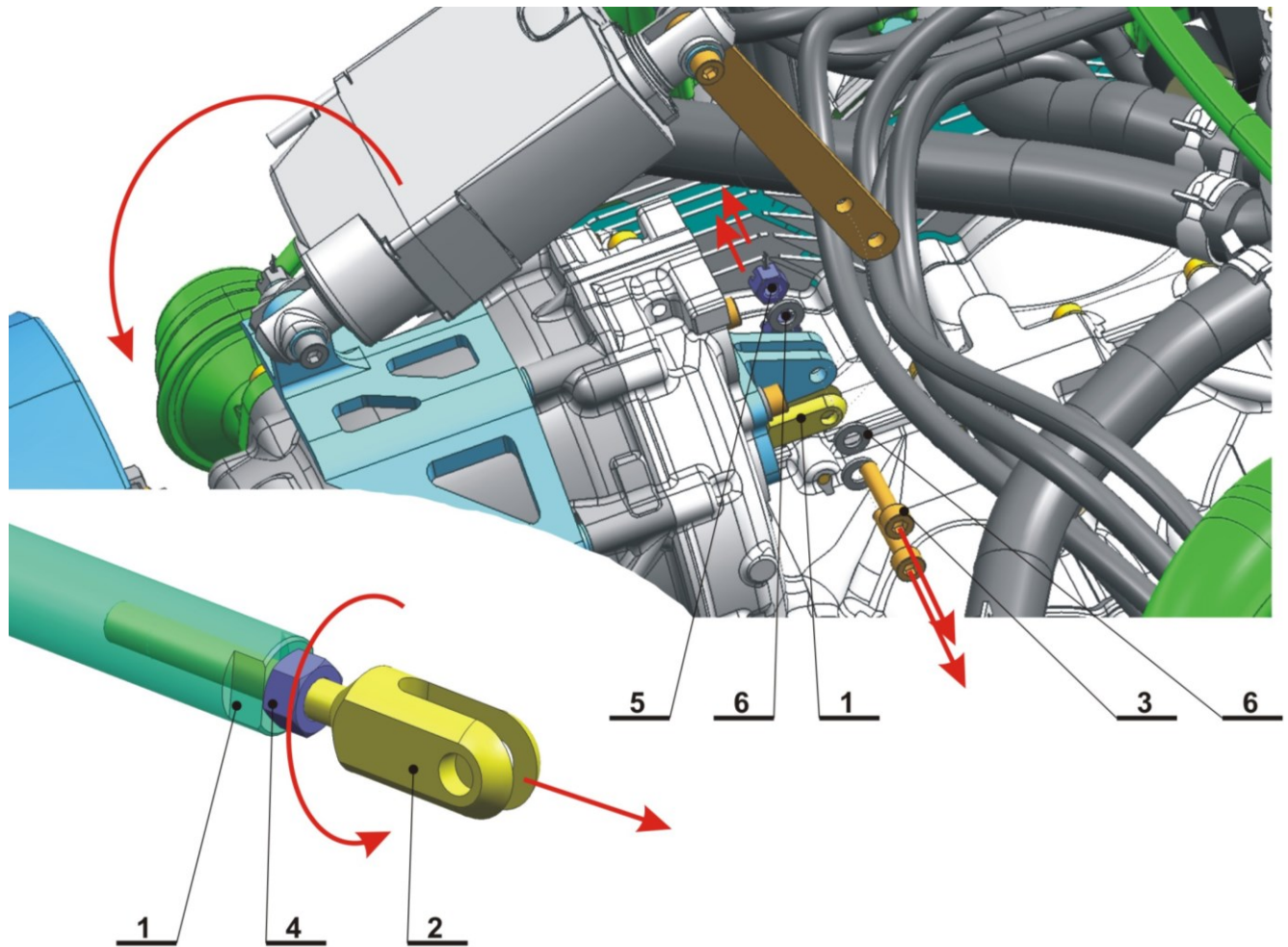

Picture no. 19 Fork of propeller control – setting

Item no.	Item/subassembly name
1	Axis of propeller control
2	Fork of propeller control
3	Screw M6 x 27 8.8 DIN 912
4	Nut M6 hexagonal ISO 4032
5	Crown nut M6 ČSN 02 1411 with pin
6	Washer M 6

After adjusting the fork of servo motor control make up again the control unit and secure the crown nuts with pins.

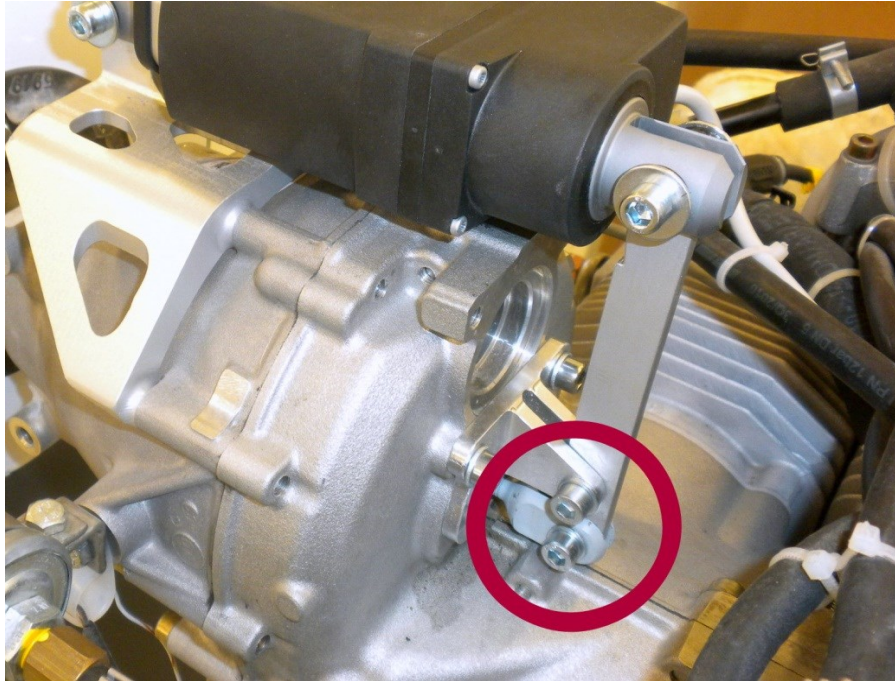

Picture no. 20 Complete unit of propeller control

After finishing all actions in point 15.9. repeat step 15.8. propeller installation onto the aircraft.

15.10. Detected speed are lower than given tolerance

In this case it is necessary to dismantle the screw M6 x 40 and servo motor case – long which is secured with a crown nut M6 with pin. After then it is possible to deflect the whole servo motor around its piston fixing to the servo motor reversible handle. Turn with the free servo motor fork and set its right position. Finally make up again the joint of servo motor with servo motor holder and secure with crown nut with pin.

After finishing all actions in point 15.10. repeat step 15.8. propeller installation onto the aircraft.

15.11. Nut tightening

If the engine speed with installed propeller justify the requests specified in point 15.8. propeller installation onto the aircraft, tighten the nut M 12 marked in the following picture.

WARNING:

Do not tighten the nut M 12 using a force, the washer between the lid of propeller hub and this nut must rotate freely.

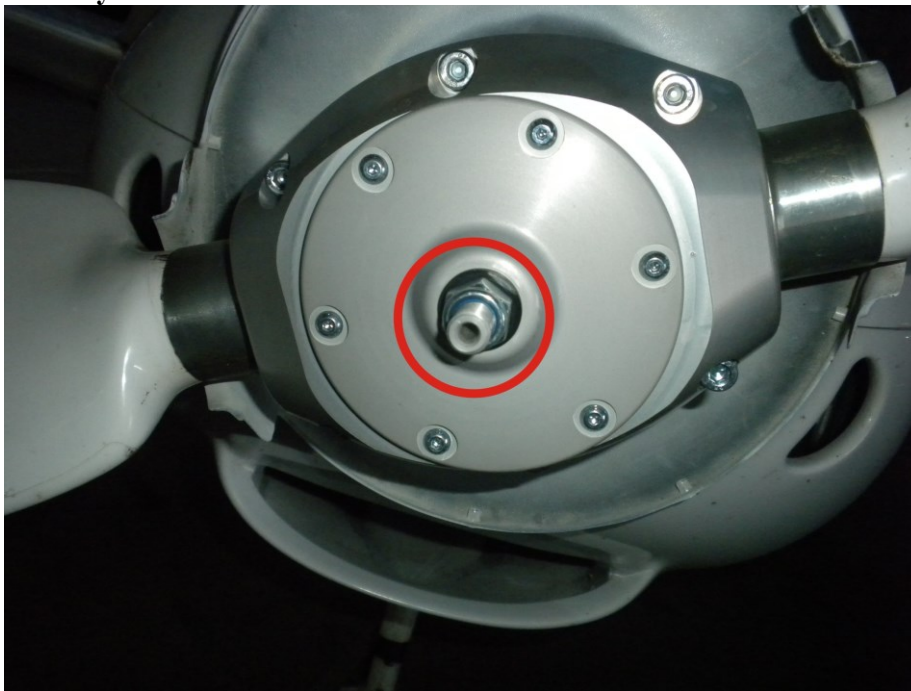

Picture no. 21 Nut M 12 tightening

15.12. Propeller spinner cover

Install the propeller spinner cover onto the propeller spinner base using 8 screws located around the cover. By assembly centre axially the propeller spinner cover.

	Document: User and installation manual	Type of propeller: DuoMax
---	---	------------------------------

15.13. Inspection and record

Try again the right propeller functionality. Write a note of propeller installation with date and aircraft immatriculation in the propeller record book. The installation must be signed by an authorized mechanic in the propeller record book.

P4/18/005CJ	Revision number: -	Original Issue Date: 30.11.2018 Revision Date: -	35/35
-------------	-----------------------	---	-------

